

INTERNATIONAL STANDARD

ISO 7465

Third edition
2001-12-01

Passenger lifts and service lifts — Guide rails for lift cars and counterweights — T-type

*Ascenseurs et monte-charge — Guides de cabine et de contrepoids —
Profils en T*



Reference number
ISO 7465:2001(E)

© ISO 2001

PDF disclaimer

This PDF file may contain embedded typefaces. In accordance with Adobe's licensing policy, this file may be printed or viewed but shall not be edited unless the typefaces which are embedded are licensed to and installed on the computer performing the editing. In downloading this file, parties accept therein the responsibility of not infringing Adobe's licensing policy. The ISO Central Secretariat accepts no liability in this area.

Adobe is a trademark of Adobe Systems Incorporated.

Details of the software products used to create this PDF file can be found in the General Info relative to the file; the PDF-creation parameters were optimized for printing. Every care has been taken to ensure that the file is suitable for use by ISO member bodies. In the unlikely event that a problem relating to it is found, please inform the Central Secretariat at the address given below.

© ISO 2001

All rights reserved. Unless otherwise specified, no part of this publication may be reproduced or utilized in any form or by any means, electronic or mechanical, including photocopying and microfilm, without permission in writing from either ISO at the address below or ISO's member body in the country of the requester.

ISO copyright office
Case postale 56 • CH-1211 Geneva 20
Tel. + 41 22 749 01 11
Fax + 41 22 749 09 47
E-mail copyright@iso.ch
Web www.iso.ch

Printed in Switzerland

Contents

Page

Foreword	iv
1 Scope	1
2 Normative references	1
3 Terms and definitions	1
4 Symbols and units	2
5 Manufacture and materials	3
6 Guide rails	3
7 Fishplates	14
Bibliography	16

Foreword

ISO (the International Organization for Standardization) is a worldwide federation of national standards bodies (ISO member bodies). The work of preparing International Standards is normally carried out through ISO technical committees. Each member body interested in a subject for which a technical committee has been established has the right to be represented on that committee. International organizations, governmental and non-governmental, in liaison with ISO, also take part in the work. ISO collaborates closely with the International Electrotechnical Commission (IEC) on all matters of electrotechnical standardization.

International Standards are drafted in accordance with the rules given in the ISO/IEC Directives, Part 3.

Draft International Standards adopted by the technical committees are circulated to the member bodies for voting. Publication as an International Standard requires approval by at least 75 % of the member bodies casting a vote.

Attention is drawn to the possibility that some of the elements of this International Standard may be the subject of patent rights. ISO shall not be held responsible for identifying any or all such patent rights.

International Standard ISO 7465 was prepared by Technical Committee ISO/TC 178, *Lifts, escalators, passenger conveyors*.

This third edition cancels and replaces the second edition (ISO 7465:1997), which has been technically revised.

Passenger lifts and service lifts — Guide rails for lift cars and counterweights — T-type

1 Scope

This International Standard specifies the grades and quality, the dimensional characteristics and tolerances, and the surface finish of standardized guide rails and their fishplates.

The dimensional tolerances include the tolerances on shape and dimensions, straightness, twisting and perpendicularity defects.

In addition, this International Standard defines a designation system for guide rails.

This International Standard is applicable to guide rails used in passenger lift and service lift installations to provide guiding for the car and the counterweight.

2 Normative references

The following normative documents contain provisions which, through reference in this text, constitute provisions of this International Standard. For dated references, subsequent amendments to, or revisions of, any of these publications do not apply. However, parties to agreements based on this International Standard are encouraged to investigate the possibility of applying the most recent editions of the normative documents indicated below. For undated references, the latest edition of the normative document referred to applies. Members of ISO and IEC maintain registers of currently valid International Standards.

ISO 468, *Surface roughness — Parameters, their values and general rules for specifying requirements*

ISO 630:1995, *Structural steels — Plates, wide flats, bars, sections and profiles*

ISO 1302, *Geometrical Product Specifications (GPS) — Indication of surface texture in technical product documentation*

3 Terms and definitions

For the purposes of this International Standard, the following terms and definitions apply.

3.1

guide rails

components that provide guiding for the car or the counterweight

3.2

fishplate

piece of steel used to connect the guides

4 Symbols and units

See Table 1.

Table 1 — Symbols and corresponding units of measurement used in this International Standard

Symbol	Dimension	Unit
b_1	Guide width	mm
b_2	Fishplate width	mm
b_3	Distance between the axes of the holes (in the transverse direction of the guide and of the fishplate)	mm
c	Width of the connecting part of the foot to the blade	mm
d	Hole diameter	mm
d_1	Countersinking diameter	mm
e	Distance from the rear surface to the centre of gravity	cm
f	Foot depth at its connection with the blade	mm
g	Foot depth at its extremity in a transverse plane	mm
h	Guide height at the level of the machined surface for the location of the fishplate	mm
h_1	Guide height (for cold drawn guide rail or for non-machined surface)	mm
i_{xx}	Radius of gyration corresponding to the xx axis	cm
i_{yy}	Radius of gyration corresponding to the yy axis	cm
I_{xx}	Moment of inertia of the cross-sectional area of the guide related to the xx axis	cm ⁴
I_{yy}	Moment of inertia of the cross-sectional area of the guide related to the yy axis	cm ⁴
k	Blade width	mm
l	Machined surface length for the location of the fishplate	mm
l_m	Maximum length for the junction area between the machined surface for the fishplate and the non-machined surface	mm
l_g	Length of the guide rail	mm
l_1	Fishplate length	mm
l_{2g}	Distance, in the guide longitudinal direction, between the axis of the farthest holes from the end of the guide and this end	mm
l_{2f}	Distance, in the fishplate longitudinal direction, between the axis of the farthest holes from the transverse axis of the fishplate and this axis	mm
l_{3g}	Distance, in the guide longitudinal direction, between the axis of the nearest holes from the end of the guide and this end	mm
l_{3f}	Distance, in the fishplate longitudinal direction, between the axis of the nearest holes from the transverse axis of the fishplate and this axis	mm
m_1	Width of the keyway for the junction of the guides	mm
m_2	Width of the key for the junction of the guides	mm
n	Blade height	mm
p	Foot depth (in the case of a flat foot)	mm
q_1	Linear density for a finished guide rail	kg/m

Table 1 (continued)

Symbol	Dimension	Unit
r_s	Foot radius	mm
Ra	Surface roughness (see ISO 468)	μm
S	Cross-sectional area of the guide	cm^2
t_n	t_1 to t_n tolerances for geometrical dimensions	mm
u_1	Depth of the keyway for the junction of the guides	mm
u_2	Length of the key for the junction of the guides	mm
v_{\min}	Minimum fishplate thickness (when machined)	mm
W_{xx}	Cross-sectional area modulus related to the xx axis	cm^3
W_{yy}	Cross-sectional area modulus related to the yy axis	cm^3

5 Manufacture and materials

Guide rails may be cold drawn or machined. In this International Standard, the manufacturing process for each type of guide is indicated by the letter A for cold drawn, B for machined and BE for machined, high quality.

The tensile strength of the steel raw material used shall be at least 370 N/mm^2 and not more than 520 N/mm^2 . For this purpose, it is recommended to use steel grade E235B for cold drawn guides and steel grade E275B for machined guides, in accordance with ISO 630:1995.

6 Guide rails

6.1 Designation

Guide rails complying with the requirements of this International Standard shall be designated as follows:

- 1st element: number of this International Standard — ISO 7465;
- 2nd element: guide shape — T;
- 3rd element: rounded value of the foot width with, if necessary, the number of the variant for different profiles with the same foot width — 45; 50; 70; 75; 75-3; 78; 82; 89; 90; 114; 125; 127-1; 127; 140-1; 140-2; 140-3;
- 4th element: manufacturing process: cold drawn — A;
machined — B;
- 5th element: Machined high quality types — E.

EXAMPLES

Lift guide rail ISO 7465-T140-1/B

Lift guide rail ISO 7465-T82/A

Lift guide rail ISO 7465-T125/BE

6.2 Dimensional characteristics and tolerances

6.2.1 Length

The length of the guide shall be indicated in millimeters with a tolerance of ± 2 mm.

It is recommended to supply in bars of 5 000 mm length.

6.2.2 Dimensions

See Tables 2 to 8.

Two series of dimensions are proposed:

- preferred dimensions: designations without parentheses. e.g. T82/A;
- non-preferred dimensions: designations between parentheses. e.g. (T89/A) – (T82/A)

Guide rails with other dimensions can be delivered on specific agreement between the guide rails manufacturer and the customer.

6.2.2.1 Cold drawn parallel foot and blade flange guide rail

See Figure 1 and Tables 2 and 3.

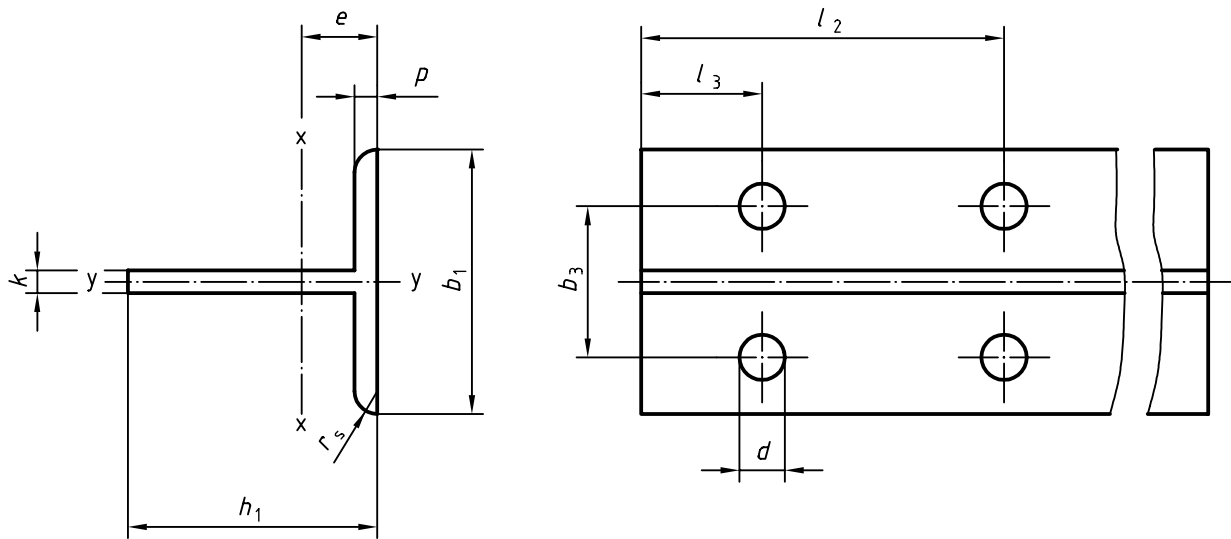

Figure 1 — Cold drawn parallel foot and blade flange guide rail

Table 2 — Technical characteristics of guide rails (see Figure 1)

Designation	S cm ²	q_1 kg/m	e cm	I_{xx} cm ⁴	W_{xx} cm ³	i_{xx} cm	I_{yy} cm ⁴	W_{yy} cm ³	i_{yy} cm
(T45/A)	4,25	3,34	1,31	8,08	2,53	1,38	3,84	1,71	0,95
T50/A	4,75	3,73	1,43	11,24	3,15	1,54	5,25	2,1	1,05

Table 3 — Dimensions and tolerances of guide rails (see Figure 1)

Dimensions in millimetres

Designation	b_1	h_1	k	p	r_s	l_{2g}	l_{3g}	d	b_3
	Tolerances								
	± 0,5	± 0,2	± 0,15	± 0,5		± 0,2	± 0,2		± 0,2
(T45/A)	45	45	5	5	1	65	15	9	25
T50/A	50	50	5	5	1	75	25	9	30

NOTE l_{2g}, l_{3g}, d, b_3 dimensions are identical and with the same tolerances as for fishplate dimensions.

6.2.2.2 Cold drawn inclined foot flange guide rail

See Figure 2 and Tables 4 and 5.

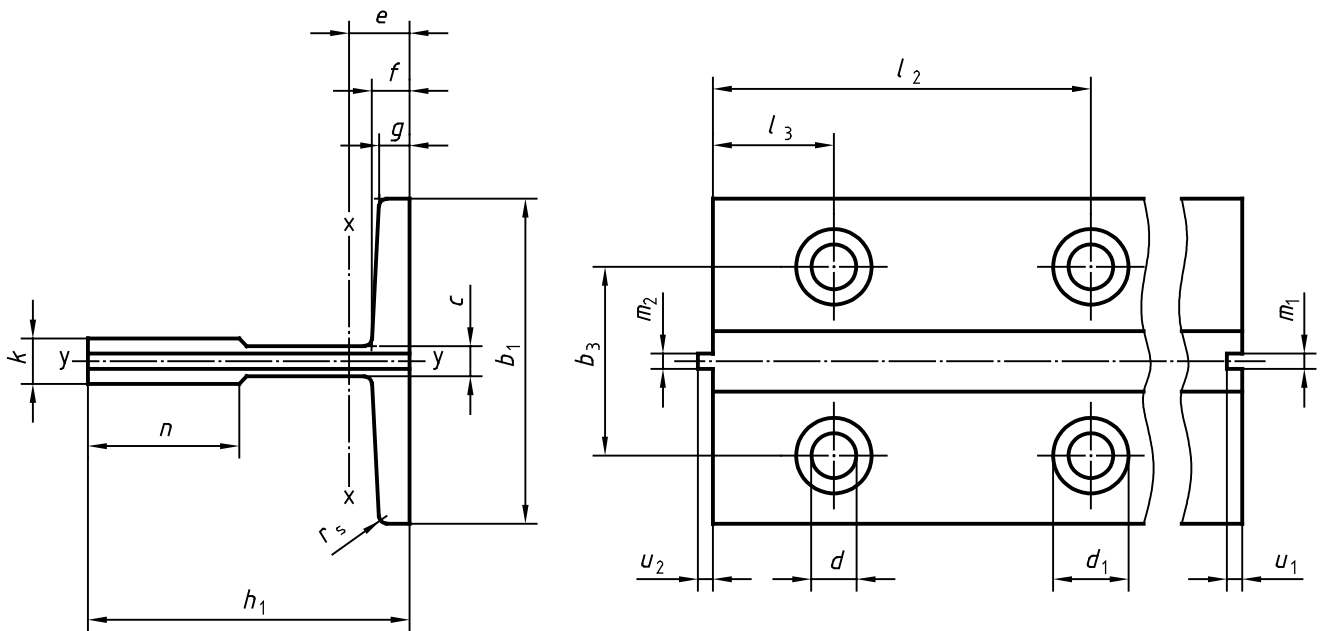

Figure 2 — Cold drawn inclined foot flange guide rail

Table 4 — Technical characteristics of guide rails (see Figure 2)

Designation	S cm ²	q_1 kg/m	e cm	I_{xx} cm ⁴	W_{xx} cm ³	i_{xx} cm	I_{yy} cm ⁴	W_{yy} cm ³	i_{yy} cm
T70/A	9,51	7,47	2,04	41,3	9,24	2,09	18,65	5,35	1,4
(T75/A)	10,99	8,63	1,86	40,35	9,29	1,92	26,49	7,06	1,55
T82/A	10,90	8,55	1,98	49,60	10,30	2,13	30,7	7,4	1,67
(T89/A)	15,7	12,30	2,02	59,52	14,25	1,95	52,4	11,8	1,83
(T90/A)	17,3	13,55	2,61	102	20,87	2,43	53	11,8	1,75

Table 5 — Dimensions and tolerances of guide rails (see Figure 2)

Dimensions in millimetres

Designation	b_1	h_1	k	n	c	f	g	m_1	m_2	u_1	u_2	d	d_1	b_3	l_{2g}	l_{3g}	r_s
	Tolerances																
	$\pm 1,5$	$\pm 0,1$	$\begin{smallmatrix} +0,1 \\ 0 \end{smallmatrix}$	$\begin{smallmatrix} +3 \\ 0 \end{smallmatrix}$		$\pm 0,75$	$\pm 0,75$	$\begin{smallmatrix} +0,06 \\ 0 \end{smallmatrix}$	$\begin{smallmatrix} 0 \\ -0,06 \end{smallmatrix}$	$\pm 0,10$	$\pm 0,10$			$\pm 0,2$	$\pm 0,2$	$\pm 0,2$	
T70/A	70	65	9	34	6	8	6	3	2,97	3,5	3	13	26	42	105	25	1,5
(T75/A)	75	62	10	30	8	9	7	3	2,97	3,5	3	13	26	42	105	25	1,5
T82/A	82	68	9	34	7,5	8,25	6	3	2,97	3,5	3	13	26	50,8	81	27	3
(T89/A)	89	62	16	34	10	11,1	7,9	6,4	6,37	7,14	6,35	13	26	57,2	114,3	38,1	3
(T90/A)	90	75	16	42	10	10	8	6,4	6,37	7,14	6,35	13	26	57,2	114,3	38,1	4

NOTE l_{2g} , l_{3g} , d , b_3 dimensions are identical and with the same tolerances as for fishplate dimensions.

6.2.2.3 Machined guide rail

See Figure 3 and Tables 6, 7 and 8.

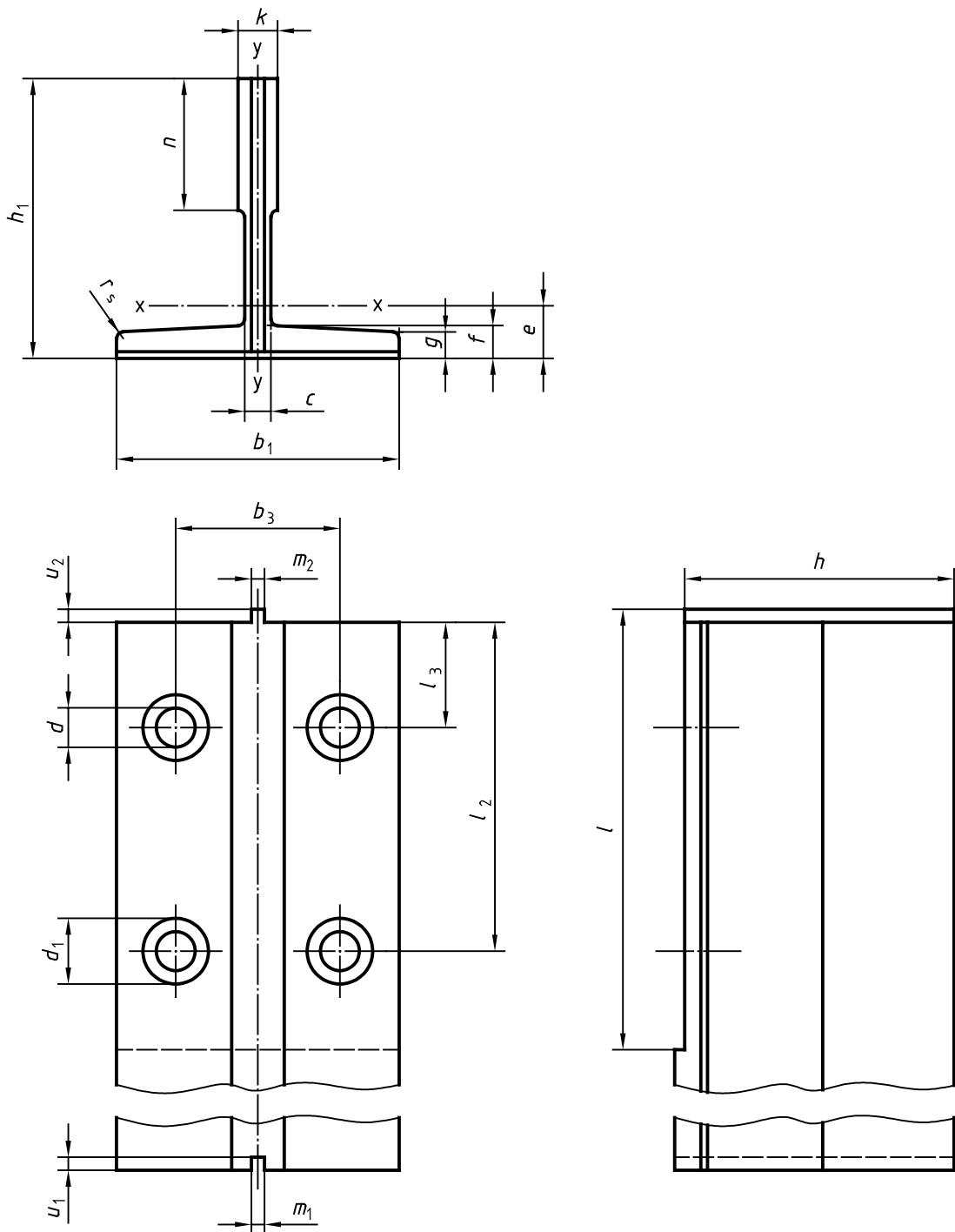

Figure 3 — Machined guide rail

Table 6 — Technical characteristics for machined guide rails (see Figure 3)

Designation	S cm ²	q_1 kg/m	e cm	I_{xx} cm ⁴	W_{xx} cm ³	i_{xx} cm	I_{yy} cm ⁴	W_{yy} cm ³	i_{yy} cm
(T75-3/B)	10,99	8,63	1,86	40,35	9,29	1,92	26,49	7,06	1,55
(T78/B)	9,84	7,72	1,65	29,9	7,56	1,47	26,1	6,71	1,63
T89/B	15,7	12,3	2,02	59,52	14,25	1,95	52,4	11,8	1,83
(T90/B)	17,3	13,55	2,61	102	20,87	2,43	53	11,8	1,75
(T114/B)	20,8	16,31	2,87	179	29,7	2,93	108	19,1	2,28
T125/B or BE	22,83	17,9	2,43	151,0	26,2	2,57	159	25,4	2,64
(T127-1/B or BE)	22,64	17,77	2,75	186,2	30,4	2,87	148	23,4	2,56
T127/B or BE	28,63	22,48	2,47	198,4	30,9	2,63	230	36,2	2,83
T140-1/B or BE	35,5	27,9	3,23	404	53,4	3,37	310	44,3	2,95
T140-2/B or BE	43,44	34,1	3,47	457	68	3,24	358	51,2	2,87
T140-3/B or BE	58,57	46	4,38	953	114,6	4,03	486	69,4	2,88

Table 7 — Dimensions and tolerances of guide rails (see Figure 3)

Dimensions in millimetres

Designation	b_1	h_1	k	n	c	f	g	r_s
(T75-3/B)	75	62	10	30	8	9	7	3
(T78/B)	78	56	10	26	7	8,5	6	2,5
T89/B	89	62	16	34	10	11,1	7,9	3
(T90/B)	90	75	16	42	10	10	8	4
(T114/B)	114	89	16	38	9,5	11	8	4
T125/B or BE	125	82	16	42	10	12	9	4
(T127-1/B or BE)	127	89	16	45	10	11	8	4
T127/B or BE	127	89	16	51	10	15,9	12,7	5
T140-1/B or BE	140	108	19	51	12,7	15,9	12,7	5
T140-2/B or BE	140	102	28,6	51	17,5	17,5	14,5	5
T140-3/B or BE	140	127	31,75	57	19	25,4	17,5	5
Tolerances								
B Class	± 1,5	± 0,75	$\begin{smallmatrix} +0,1 \\ 0 \end{smallmatrix}$	$\begin{smallmatrix} +3 \\ 0 \end{smallmatrix}$	—	± 0,75	± 0,75	—
BE Class	± 1,5	± 0,75	$\begin{smallmatrix} +0,05 \\ 0 \end{smallmatrix}$	$\begin{smallmatrix} +3 \\ 0 \end{smallmatrix}$	—	± 0,75	± 0,75	—

Table 8 — Dimensions and tolerances of guide rails (see Figure 3)

Dimensions in millimetres

Designation	m_1	m_2	u_1	u_2	d	d_1	b_3	l_{2g}	l_{3g}	l	h
(T75-3/B)	3	2,95	3,5	3	13	26	43	90	30	123	61
(T78/B)	3	2,95	3,5	3	13	26	43	90	30	123	55
T89/B	6,4	6,37	7,14	6,35	13	26	57,2	114,3	38,1	156	61
(T90/B)	6,4	6,37	7,14	6,35	13	26	57,2	114,3	38,1	156	74
(T114/B)	6,4	6,37	7,14	6,35	17	33	70	114,3	38,1	156	88
T125/B or BE	6,4	6,37	7,14	6,35	17	33	79,4	114,3	38,1	156	81
(T127-1/B or BE)	6,4	6,37	7,14	6,35	17	33	79,4	114,3	38,1	156	88
T127/B or BE	6,4	6,37	7,14	6,35	17	33	79,4	114,3	38,1	156	88
T140-1/B or BE	6,4	6,37	7,14	6,35	21	40	92,1	152,4	31,8	193	107
T140-2/B or BE	6,4	6,37	7,14	6,35	21	40	92,1	152,4	31,8	193	101
T140-3/B or BE	6,4	6,37	7,14	6,35	21	40	92,1	152,4	31,8	193	126
Tolerances											
B Class	$\begin{matrix} +0,06 \\ 0 \end{matrix}$	$\begin{matrix} 0 \\ -0,06 \end{matrix}$	$\pm 0,10$	$\pm 0,10$	—	—	$\pm 0,2$	$\pm 0,2$	$\pm 0,2$	$\begin{matrix} +3 \\ 0 \end{matrix}$	$\pm 0,1$
BE Class	$\begin{matrix} +0,03 \\ 0 \end{matrix}$	$\begin{matrix} 0 \\ -0,03 \end{matrix}$	$\pm 0,10$	$\pm 0,10$	—	—	$\pm 0,2$	$\pm 0,2$	$\pm 0,2$	$\begin{matrix} +3 \\ 0 \end{matrix}$	$\pm 0,05$

6.2.3 Machined surface for the location of the fishplate (for machined guide rails)

See Figure 4.

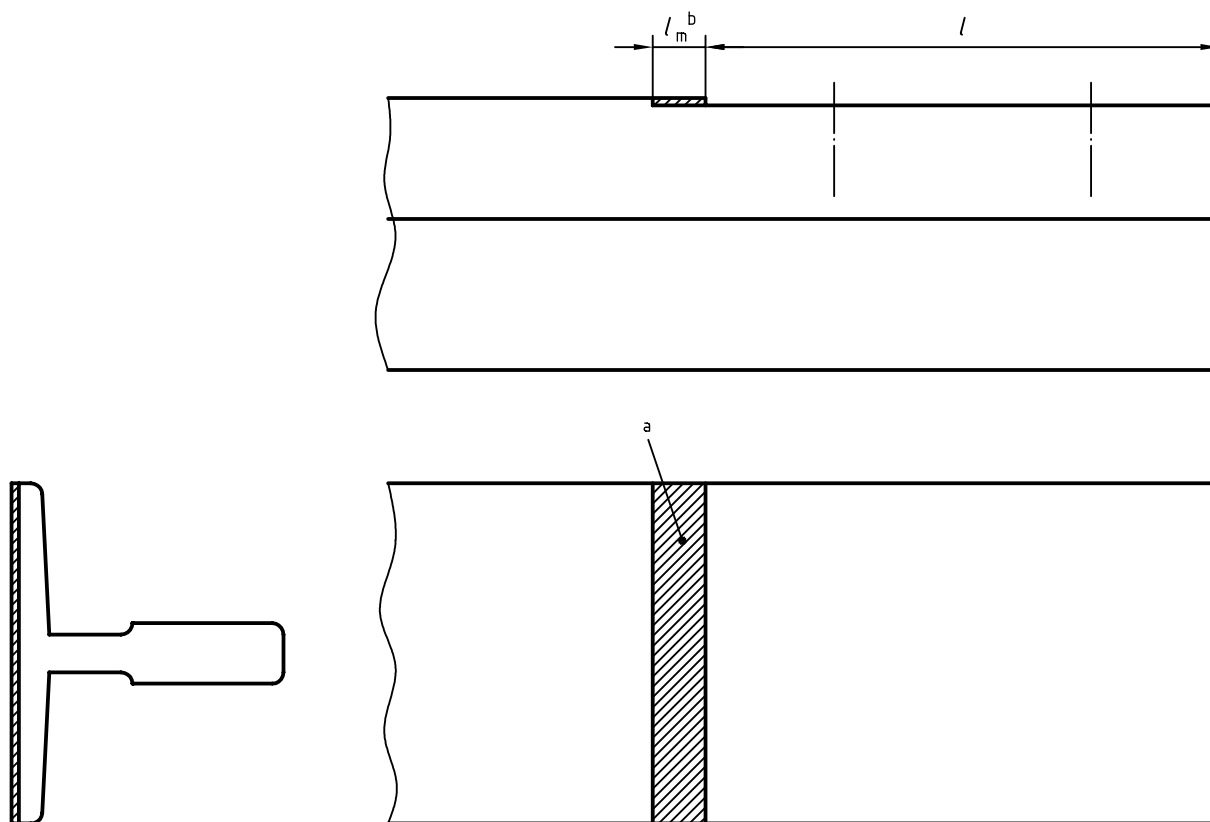

^a The junction between the machined surface for the location of the fishplate and the non-machined rear surface of the foot is located in this volume.

^b $l_m = 40$ mm.

Figure 4 — Machined surface for the location of the fishplate

6.2.4 Blade shape

The blade shall be chamfered or rounded taking into account the values:

- length of the chamfer side: 1 mm maximum or
- radius: 1 mm maximum.

6.2.5 Surface finish

Guide rails shall have the following surface finishes as specified in ISO 468 and in accordance with the roughness grades specified in ISO 1302.

6.2.5.1 Guide rail blade roughness

See Table 9.

Table 9 — Guide rail blade roughness

Guide rail class	Blade roughness	
	Direction	
	Longitudinal	Transverse
A	$1,6 \mu\text{m} \leq Ra \leq 6,3 \mu\text{m}$ N7 - N9	$1,6 \mu\text{m} \leq Ra \leq 6,3 \mu\text{m}$ N7 - N9
B	$Ra \leq 1,6 \mu\text{m}$ N7	$0,8 \mu\text{m} \leq Ra \leq 3,2 \mu\text{m}$ N6 - N8
BE	$Ra \leq 1,6 \mu\text{m}$ N7	$0,8 \mu\text{m} \leq Ra \leq 3,2 \mu\text{m}$ N6 - N8

6.2.5.2 Foot rear surface of machined guide rails

Maxi roughness N9, i.e. $Ra \leq 6,3 \mu\text{m}$

6.2.6 Machined edges

All machined edges shall be deburred to avoid sharp edges.

6.2.7 Holes in guide rails

The holes shall be such that their machining will lead to no cracking or deformation in the guide rail.

6.2.8 Geometrical tolerances

See Table 10 and Figure 5.

6.3 Marking for BE class

To avoid mixing of A, B and BE classes, the BE class guide rails shall be marked up BE at least twice per bar near the end (for the A and B guide rail classes, the marking is not required).

BE Markings shall have a minimum height of 10 mm.

Table 10 — Geometrical tolerances for a 5 000 mm length guide rail, l_g

Position on Figure 5	Guide rail class			Dimensions concerned
	A	B	BE	
Tolerances				
t_1 (mm)	0,2	0,1	0,05	Blade side flatness
t_2 (mm)	7	5	2	Top of blade position
$t_3/500$ (mm/mm)	0,7	0,5	0,2	Top of blade flatness
t_4 (mm)	—	0,1	0,05	Key and keyway symmetry
t_5 (mm)	$\begin{matrix} +0,06 \\ 0 \end{matrix}$	$\begin{matrix} +0,06 \\ 0 \end{matrix}$	$\begin{matrix} +0,03 \\ 0 \end{matrix}$	Key width: m_1
t_6 (mm)	$\begin{matrix} 0 \\ -0,06 \end{matrix}$	$\begin{matrix} 0 \\ -0,06 \end{matrix}$	$\begin{matrix} 0 \\ -0,03 \end{matrix}$	Keyway width: m_2
t_7 (mm)	$\pm 0,15$	$\begin{matrix} +0,1 \\ 0 \end{matrix}$	$\begin{matrix} +0,05 \\ 0 \end{matrix}$	Blade width: k
t_8 (mm)	0,2	0,1	0,05	Machined surfaces for fishplate perpendicularity
t_9 (mm)	—	$\pm 0,1$	$\pm 0,05$	Guide height: h
t_{10} (mm)	—	0,1	0,05	Keyway perpendicularity
t_{11} (mm)	1	0,5	0,3	Distance between holes symmetry
t_{12} (mm)	$\pm 0,2$	$\pm 0,2$	$\pm 0,2$	Distance between the axis of the holes: b_3
t_{13} (mm)	—	0,1	0,5	Foot depth centering: c
t_{14} (mm)	—	$\pm 0,1$	$\pm 0,1$	Key length and keyway depth: u_1, u_2
t_{15} (mm)	$\pm 0,2$	$\pm 0,2$	$\pm 0,2$	Distances from holes to the end of guide rail: l_1, l_{2g}

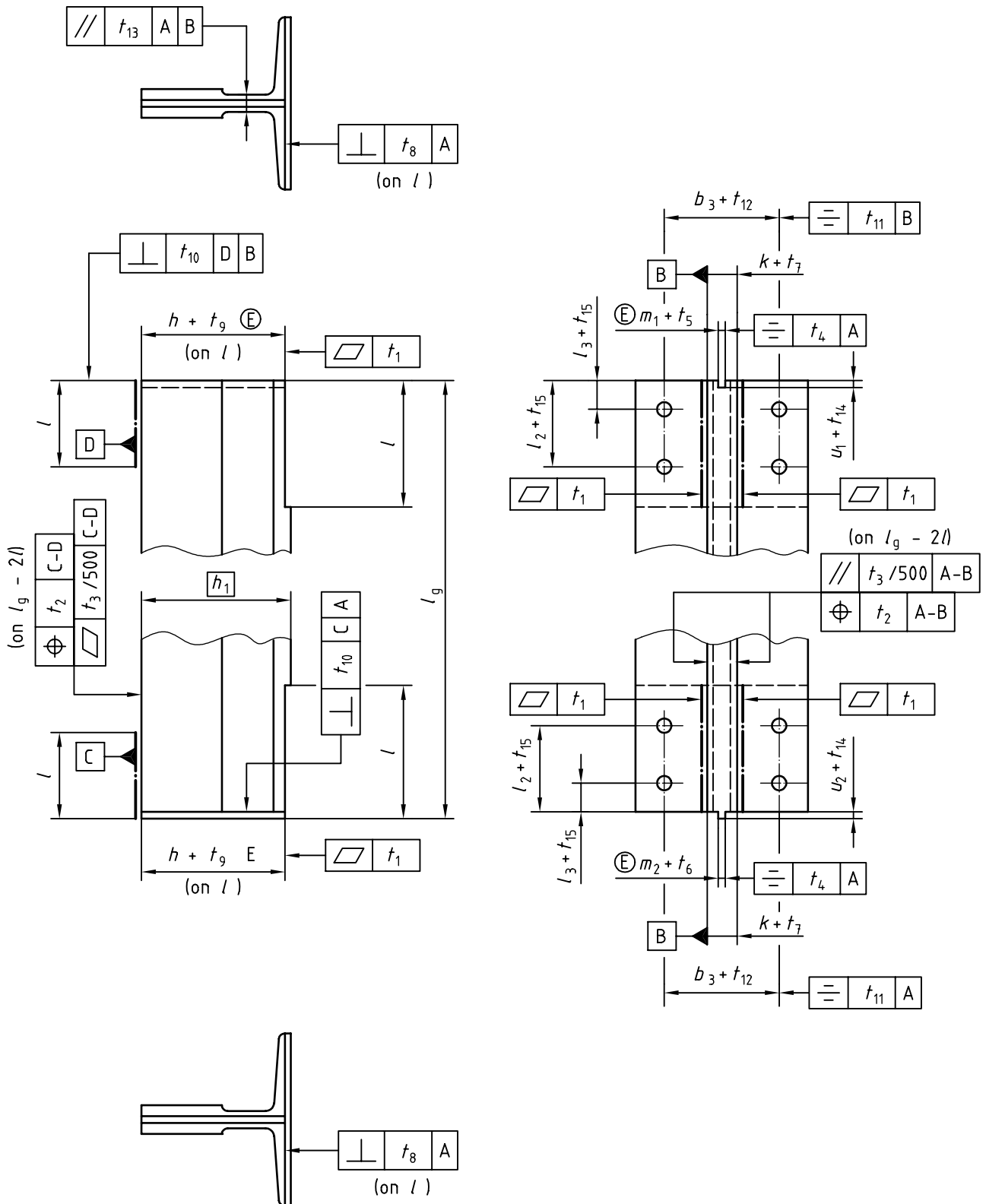

Figure 5 — Geometrical tolerances for a 5 000 mm length guide rail, l_g

7 Fishplates

7.1 Fishplate material

The steel grade shall be the same as for the guide rails (see clause 5). The tensile strength of the steel raw material used shall be at least equal to the tensile strength of the steel raw material used for the guide rails.

7.2 Fishplate dimensions

See Table 11 and Figure 6.

Table 11 — Fishplate dimensions and tolerances

Dimensions in millimetres

Guide rails designation	d_1	l_1	l_{2f}	l_{3f}	b_2	b_3	v_{\min}
	Tolerances						
	9	$\begin{matrix} +3 \\ 0 \end{matrix}$	$\pm 0,2$	$\pm 0,2$		$\pm 0,2$	
(T45/A)	9	160	65	15	50	25	8
T50/A	13	200	75	25	50	30	8
T70/A	13	250	105	25	70	42	10
(T75/A)	13	250	105	25	70	42	10
(T75-3/B)	13	240	90	30	75	43	10
(T78/B)	13	240	90	30	75	43	10
T82/A	13	216	81	27	80	50,8	10
(T89/A) T89/B	13	305	114,3	38,1	90	57,2	13
(T90/A) (T90/B)	17	305	114,3	38,1	90	57,2	13
(T114/B)	17	305	114,3	38,1	120	70	18
T125/B	17	305	114,3	38,1	130	79,4	18
T125/BE	17	305	114,3	38,1	130	79,4	28
(T127-1/B)	17	305	114,3	38,1	130	79,4	18
(T127-1/BE)	17	305	114,3	38,1	130	79,4	18
T127/B	17	305	114,3	38,1	130	79,4	18
T127/BE	21	305	114,3	38,1	130	79,4	28
T140-1/B	21	380	152,4	31,8	140	92,1	28
T140-1/BE	21	380	152,4	31,8	140	92,1	38
T140-2/B	21	380	152,4	31,8	140	92,1	28
T140-2/BE	21	380	152,4	31,8	140	92,1	38
T140-3/B	21	380	152,4	31,8	140	92,1	38

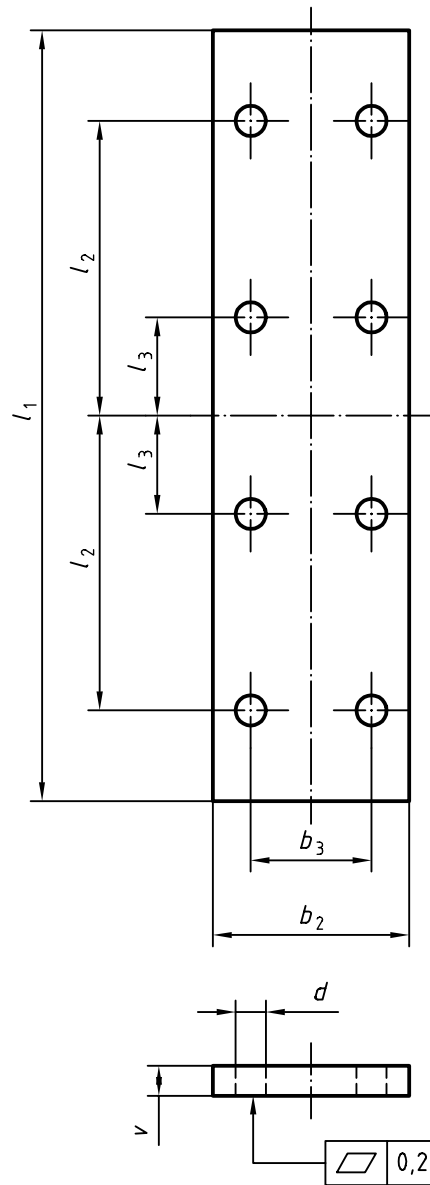

Figure 6 — Fishplate dimensions

7.3 Fishplates surface tolerances

See Figure 6.

The flatness tolerance of one side of the fishplate shall be 0,2 mm.

7.4 Fishplates holes

The holes shall be such that their machining will cause no crack or deformation in the fishplate.

Bibliography

- [1] ISO 286-1, *ISO system of limits and fits — Part 1: Bases of tolerances, deviations and fits*
- [2] ISO 1101, *Geometrical Product Specifications (GPS) — Geometrical tolerancing — Tolerances of form, orientation, location and run-out*
- [3] ISO 5458, *Geometrical Product Specifications (GPS) — Geometrical tolerancing — Positional tolerancing*
- [4] ISO 5459, *Technical drawings — Geometrical tolerancing — Datums and datum-systems for geometrical tolerances*
- [5] ISO 8015, *Technical drawings — Fundamental tolerancing principle*

